

Features

- 2:1 Wide Input Voltage Range
- 15 Watts Output Power
- 1.6kVDC Isolation
- UL Certified
- Fixed Operating Frequency
- Six-Sided Continuous Shield
- Standard 50.8 x25.4x10.2mm Package
- Efficiency to 88 %

Rev. 1

POWERLINE

DC/DC-Converter

RP15- S_DF Series

15 Watt
2" x 1" Package
Single & Dual
Output



UL-60950-1 Certified

RECOM

Description

The RP15-F series DC/DC converters are certified to UL 60950-1 and to cUL 60950-1. This makes them ideal for all telecom and industrial applications where approved safety standards are required. The industry standard 2" x 1" package meets military standards for thermal shock and vibration tolerance.

Selection Guide 12V, 24V and 48V Input Types

Part Number	Input Range VDC	Output Voltage VDC	Output Current mA	Input ⁽⁴⁾ Current mA	Efficiency ⁽⁵⁾ %	Capacitive ⁽⁶⁾ Load max.
RP15-123.3SF	9-18	3.3	4000	1467	79	10200µF
RP15-1205SF	9-18	5	3000	1603	82	7050µF
RP15-1212SF	9-18	12	1250	1524	86	1035µF
RP15-1215SF	9-18	15	1000	1524	86	705µF
RP15-243.3SF	18-36	3.3	4000	724	80	10200µF
RP15-2405SF	18-36	5	3000	781	84	7050µF
RP15-2412SF	18-36	12	1250	772	85	1035µF
RP15-2415SF	18-36	15	1000	772	85	705µF
RP15-483.3SF	36-75	3.3	4000	357	81	10200µF
RP15-4805SF	36-75	5	3000	396	83	7050µF
RP15-4812SF	36-75	12	1250	377	87	1035µF
RP15-4815SF	36-75	15	1000	381	86	705µF
RP15-1205DF	9-18	±5	±1500	1582	83	±1020µF
RP15-1212DF	9-18	±12	±625	1524	86	±495µF
RP15-1215DF	9-18	±15	±500	1563	84	±165µF
RP15-2405DF	18-36	±5	±1500	781	84	±1020µF
RP15-2412DF	18-36	±12	±625	762	86	±495µF
RP15-2415DF	18-36	±15	±500	762	86	±165µF
RP15-4805DF	36-75	±5	±1500	386	85	±1020µF
RP15-4812DF	36-75	±12	±625	372	88	±495µF
RP15-4815DF	36-75	±15	±500	377	87	±165µF

* add /P for CTRL function with Positive Logic (1=ON, 0=OFF)

* add /N for CTRL function with Negative Logic (0=ON, 1=OFF)

* add suffix -HC for premounted heatsink and clips

Ordering Examples

RP15-2405SF/P = 24V Input, 5V Output, Positive Logic CTRL pin fitted

RP15-4805DF-HC = 48V Input, ±5V Output, No CTRL pin, Heatsink fitted

Derating Graph (Ambient Temperature)

RP15-4805SF

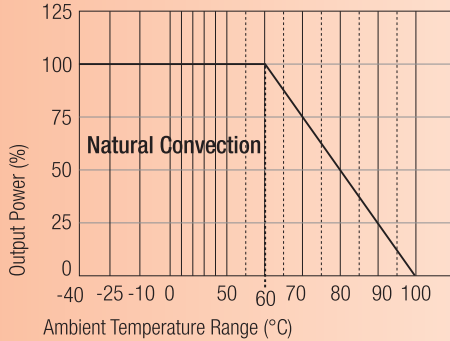

RP15-4805SF With Heat Sink

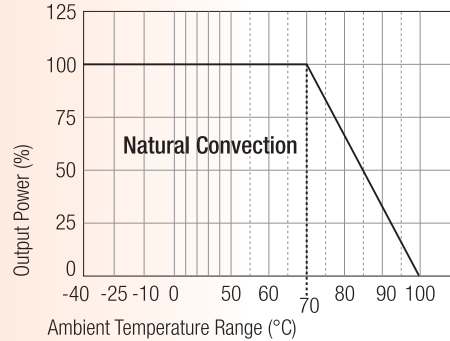

Derating graphs are valid only for the shown part numbers. If you need detailed derating-information about a part-number not shown here please contact our technical customer service at info@recom-development.at

Typical Characteristics

RP15-4805SF

Efficiency VS Input Voltage

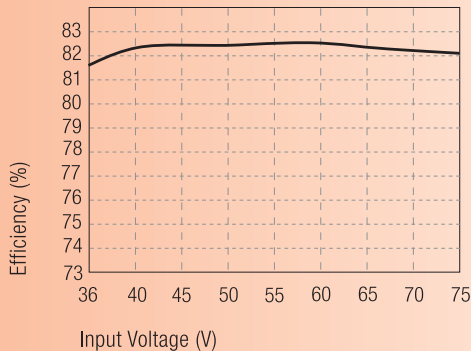

RP15-4805SF

Efficiency VS Output load

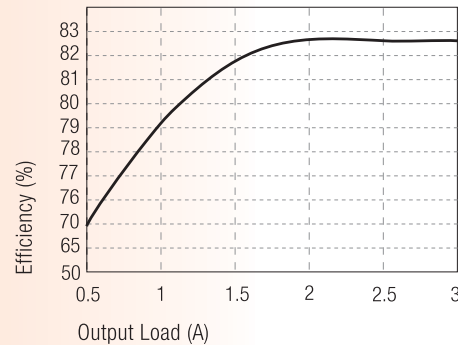

Specifications (typical at nominal input and 25°C unless otherwise noted)

Input Voltage Range	12V nominal input	9-18VDC
	24V nominal input	18-36VDC
	48V nominal input	36-75VDC
Input Filter		Pi Type
Input Surge Voltage (100 ms max.)	12V Input	36VDC
	24V Input	50VDC
	48V Input	100VDC
Input Reflected Ripple (nominal Vin and full load) (see Note 3)		20mA _{p-p}
Start Up Time (nominal Vin and constant resistor load)		20ms typ.
Remote ON/OFF (Optional. See Note 7)		
(Positive logic)	DC-DC ON	Open or 3.5V < Vr < 12V
	DC-DC OFF	Short or 0V < Vr < 1.2V
(Negative logic)	DC-DC ON	Short or 0V < Vr < 1.2V
	DC-DC OFF	Open or 3.5V < Vr < 12V
Remote OFF input current	Nominal input	20mA
Output Power		15W max.

continued on next page

Specifications (typical at nominal input and 25°C unless otherwise noted)

Output Voltage Accuracy (full Load and nominal Vin)		±1%
Minimum Load (see Note 1)		10% of full load
Line Regulation (low line, high line at full load)		±1%
Load Regulation (25% to 100% full load)	Single	±1%
	Dual	±2%
Cross Regulation (asymmetrical load 25%/100% full load)		±5%
Ripple and Noise (20MHz bandwidth)	Single	50mVp-p
	Dual	75mVp-p
Temperature Coefficient		±0.02%/°C max.
Transient Response (25% load step change)		500µs
Over Voltage Protection	3.3V	3.9V
Zener diode clamp (only single)	5V	6.2V
	12V	15V
	15V	18V
Over Load Protection (% of full load at nominal Vin)		150% typ
Undervoltage Lockout		none
Short Circuit Protection		Hiccup, automatic recovery
Efficiency		see „Selection Guide“ table
Isolation Voltage		1600VDC min.
Isolation Resistance		1 GΩ min.
Isolation Capacitance		300pF max.
Operating Frequency	Single	500kHz typ.
	Dual	300kHz typ.
Approved to Safety Standards		UL 1950, EN60950
Operating Temperature Range		-40°C to +85°C(with derating)
Maximum Case Temperature		+100°C
Storage Temperature Range		-55°C to +105°C
Thermal Impedance	Natural convection	12°C/Watt
(see Note 8)	Natural convection with Heat Sink	10°C/Watt
Thermal Shock		MIL-STD-810D
Vibration		10-55Hz, 10G, 30 Min. along X, Y and Z
Relative Humidity		5% to 95% RH
Case Material		Nickel plated copper
Base Material		Non-conductive black plastic
Potting Material		Epoxy (UL94-V0)
Conducted Emissions (see Note 9)	EN55022	Level A
Radiated Emissions	EN55022	Level A
ESD	EN61000-4-2	Perf. Criteria 2
Radiated Immunity	EN61000-4-3	Perf. Criteria 2
Fast Transient	EN61000-4-4	Perf. Criteria 2
Surge	EN61000-4-5	Perf. Criteria 2
Conducted Immunity	EN61000-4-6	Perf. Criteria 2

continued on next page

Specifications (typical at nominal input and 25°C unless otherwise noted)

Weight	27g
Dimensions	50.8 x 25.4 x 10.2mm
MTBF (see Note 2)	2041 x 10 ³ hours

Notes :

1. The RP15 series requires a minimum of 10% loading on the output to maintain specified regulation. Operation under no-load condition will not damage these devices, however they may not meet all listed specification.
2. BELLCORE TR-NWT-000332. Case I: 50% Stress, Temperature at 40°C (Ground fixed and controlled environment).
3. Simulated source impedance of 12μH. 12μH inductor in series with +Vin.
4. Maximum value at nominal input voltage and full load of standard type.
5. Typical value at nominal input voltage and full load.
6. Test by minimum Vin and constant resistor load.
7. The ON/OFF control function can be positive or negative logic. The pin voltage is referenced to negative input.
 - Positive logic ON/OFF is marked with suffix-P (eg. RP15-2405SF/P)
 - Negative logic ON/OFF is marked with suffix-N (eg. RP15-2405SF/N).
 - If no suffix is specified, the control pin will be omitted.
8. Heat sink is optional and P/N: 7G-0020A. Powerline DC/DC Converters can be ordered with pre-mounted heatsinks including antivibration fixing clips (add suffix -HC). See Application Notes for heatsink details.
9. See application notes for EMI-filtering.

Package Style and Pinning (mm)

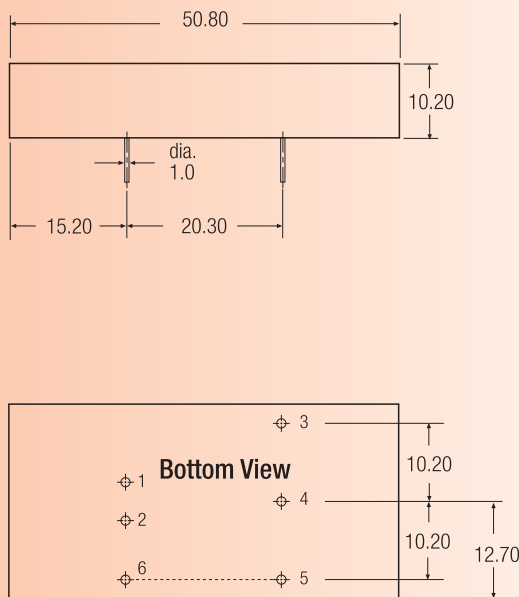

Pin Connections

Pin #	Single	Dual
1	+Vin	+Vin
2	-Vin	-Vin
3	+Vout	+Vout
4	No Pin	Com
5	-Vout	-Vout
6*	CTRL*	CTRL*

* Optional. See Note 7.

Pin Pitch Tolerance ±0.35 mm